

Description: BONNIE'S PURSE: is a useful basic purse with fabric handles and inside pockets. This “no-frills” purse is an excellent companion to “Bonnie's Billfold” - see additional pattern for Billfold construction.

SUPPLY LIST

5/8 yds of quilted material
3 “ x 27” unquilted fabric
12 ” zipper
40 ” Steam-A-Seam2, double stick fusible Web
Matching Thread

OPTIONAL 3 ½ 13 ½ “ fabric for bands

CUTTING DIRECTIONS

From Quilted fabric:

Body: 2 - 14” tall x 13 ½ “ wide



right side *



wrong side

Pockets: 2 – 6 ½ “ tall x 13 ½ “ wide



right side



wrong side

Handles: 2 – 4” tall x 42” wide



From Non-quilted fabric

Binding: 2 1/4" tall x 27" wide



CONSTRUCTION

Handles:

Make handles by ironing fabric folded in center the long way.

Fold line

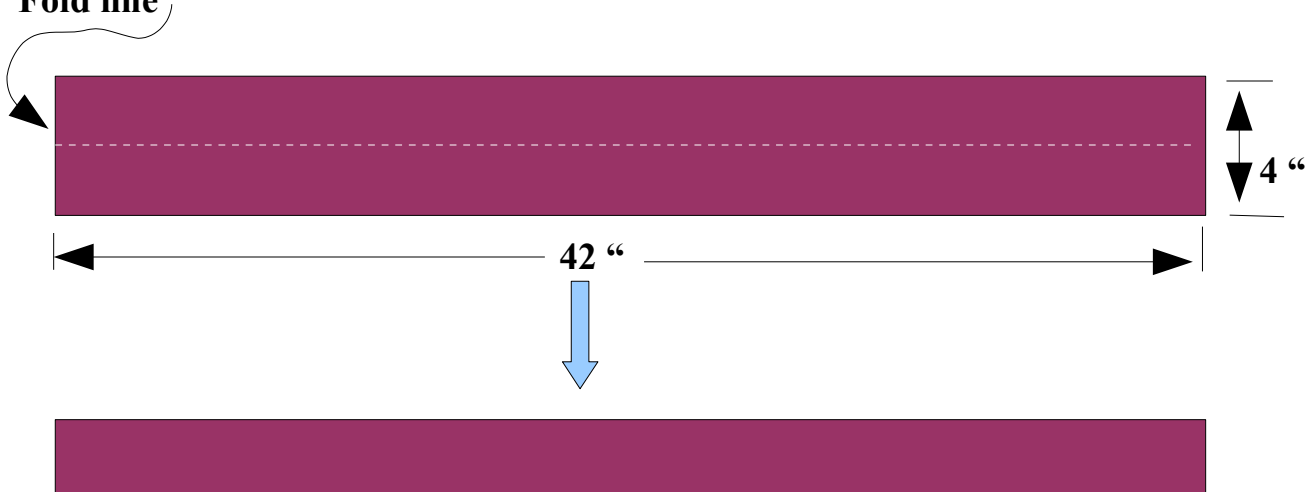

Open up and fold in each half. Fold lines

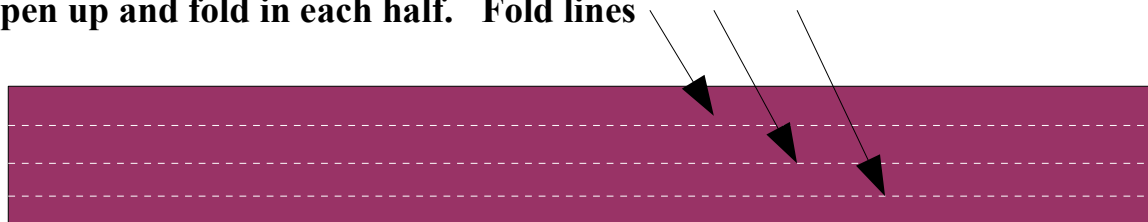

Fold in sides toward center and fold again. Side view should look like this:



Finish bringing edges together.



Pin and edge stitch both edges. – Then stitch again down the middle -

Top view:

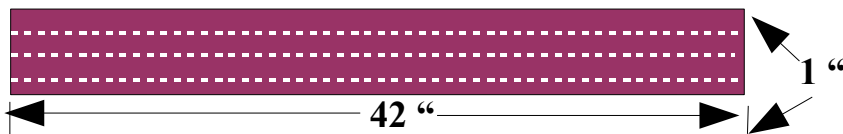

Note that the above is a magnified view of the one inch wide handle. You should have two handles ~42 " x 1 " . Set aside.

Pockets:

Bind tops of each pocket with non-quilted material

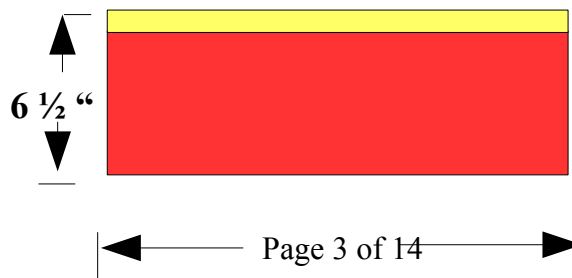

Place right side of pocket raw edge 3 ¼ “ from bottom of wrong side of body.

Center and stitch across with ¼ seam allowance

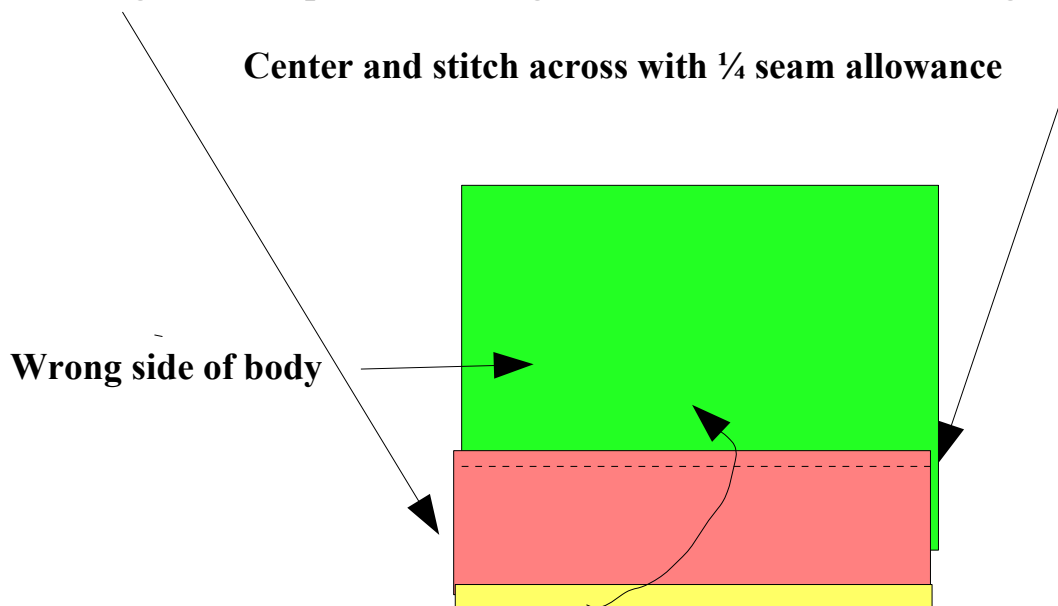

Now, flip up pocket, iron and edge stitch across seam just sewn.

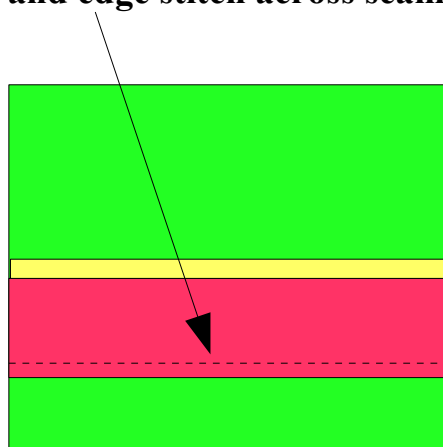

Position Handles for sewing 3 " in from each side
Attach Handles to outside (right side) of body by (1) stitching $\frac{1}{4}$ seam
across and 3 " up from bottom tacking the handles to the right side of body.

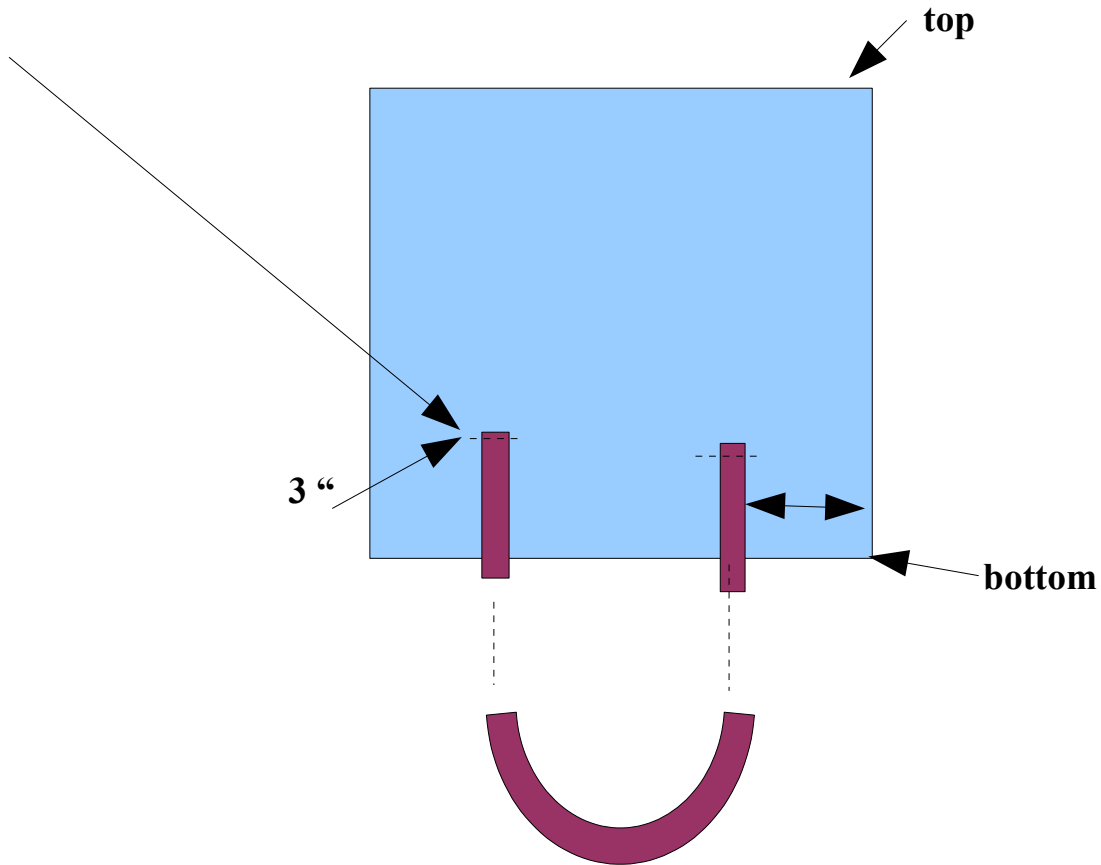

Then flip up handles and edge seam to body.

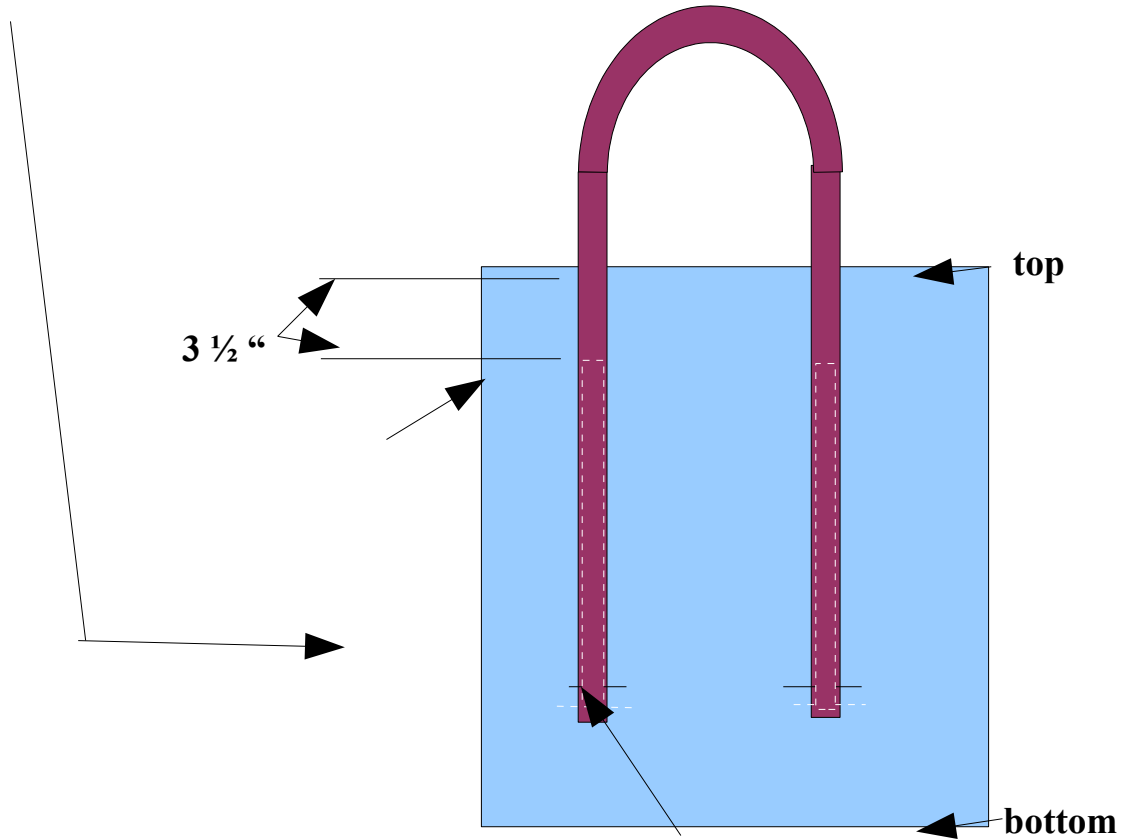

Then edge stitch rest of handle from bottom to 3 1/2 " from top of purse in a rectangle pattern. Note: stop stitches 3 1/2 " from top.

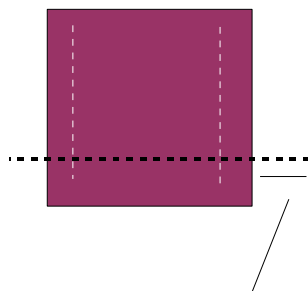

Magnified view: lower end of handle folded back and stitched to body. Then flipped up and sewn to body in rectangular pattern

This make three pockets on inside

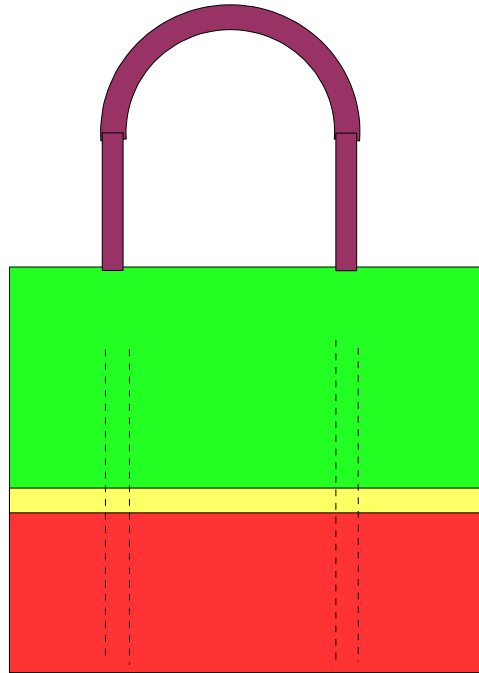

Zipper Section:

Fold handles out of the way.

Test “Steam-a-Seam” on scrap of fabric first.

The right side of the zipper is the side with the pull. Place “sticky” side of steam-a-seam along the top edge of the right side of the zipper (see detail below). Iron lightly, just enough to heat adherent material and fuse it to the zipper (about 20 seconds for entire zipper.) Pull off paper portion of tape leaving only adherent

material on zipper. Place zipper on top of body – see detail below

Zipper Detail

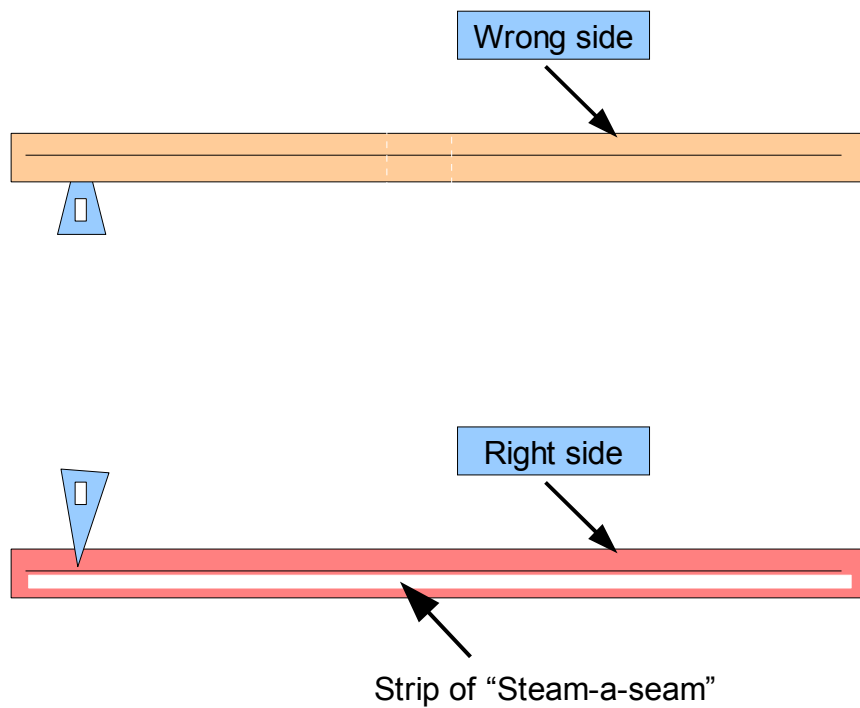

Place right side of the zipper on the right side of body and iron on the steam-a-seam tape (about 30 seconds). Iron zipper to body to adhere zipper.

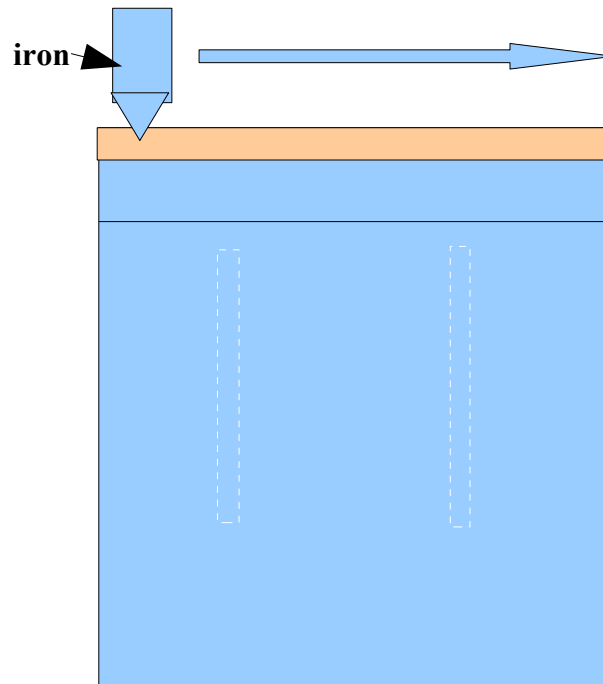

From wrong side: First sew two seams along length of zipper. Diagram shows zipper rotated 90 degrees to clockwise. Detailed view in figures below.

(1) edge stitch along length of zipper with zipper foot needle position all the way to the right and right edge of zipper foot at top edge of zipper tape.

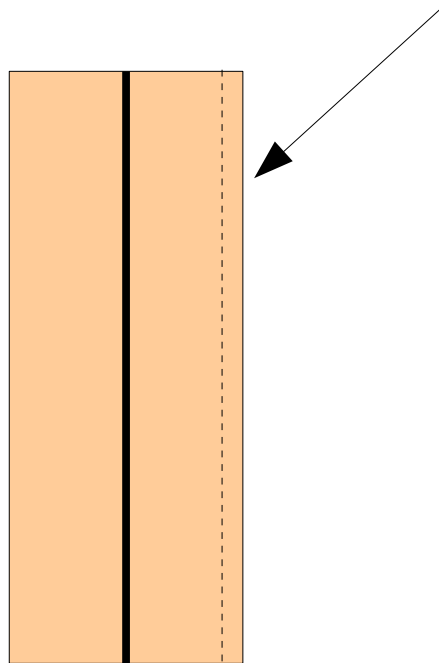

(2) Move zipper foot to left so left side of zipper foot is touching teeth of zipper and sew seam (seam allowance is approximately 1/4 ").

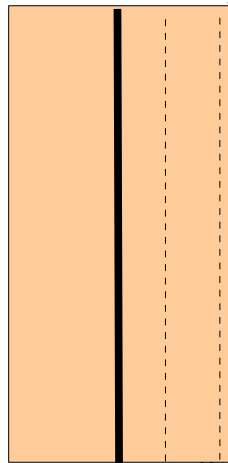

Now turn body over so you are looking at right side. Fold back right side of body, iron fold, and edge stitch along fold.

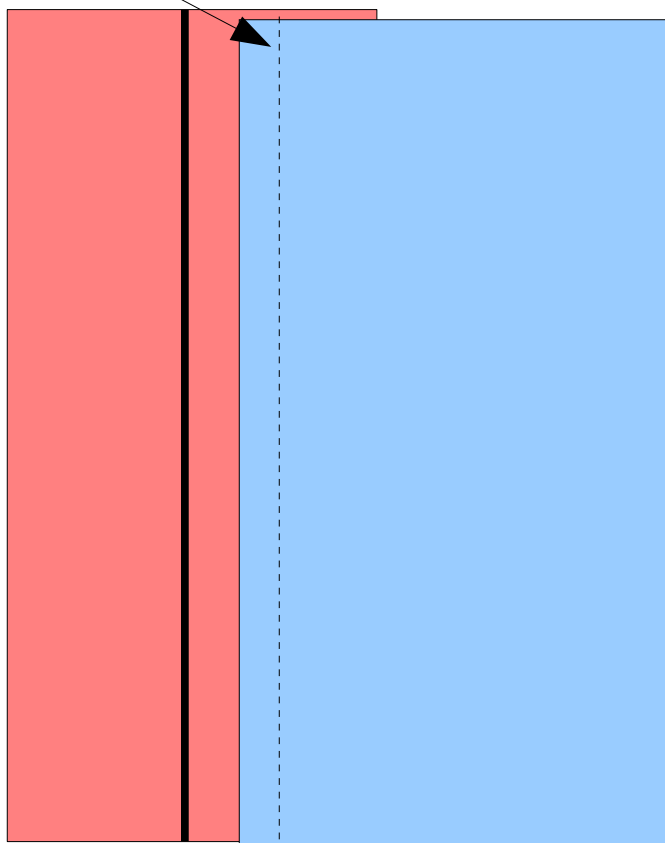

Repeat for other side if zipper. Using a similar view, the top of the zipper and body panels looks like:

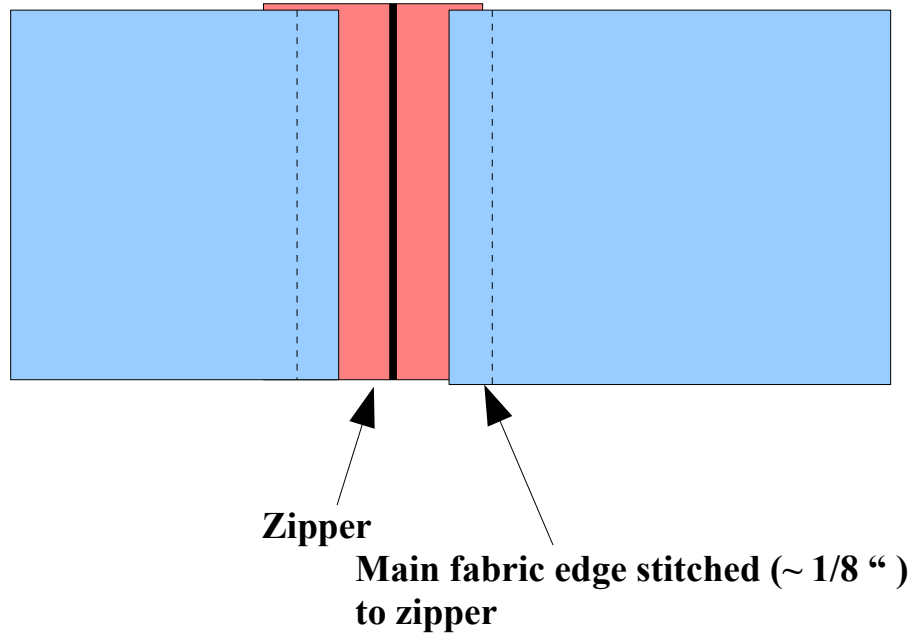

Final Assembly

**Figures now rotated back 90 degrees counter-clockwise.
Handles folded out of the way.**

You should now have the two sides of the body with handles on the right side and pockets on the wrong sides attached to each side of the zipper. Put the right sides together and match the edges. Sew the two sides together with a 1/2 " seam allowance backstitching at the start and end of the side stitches. You may find the stitching is facilitated by a walking foot.

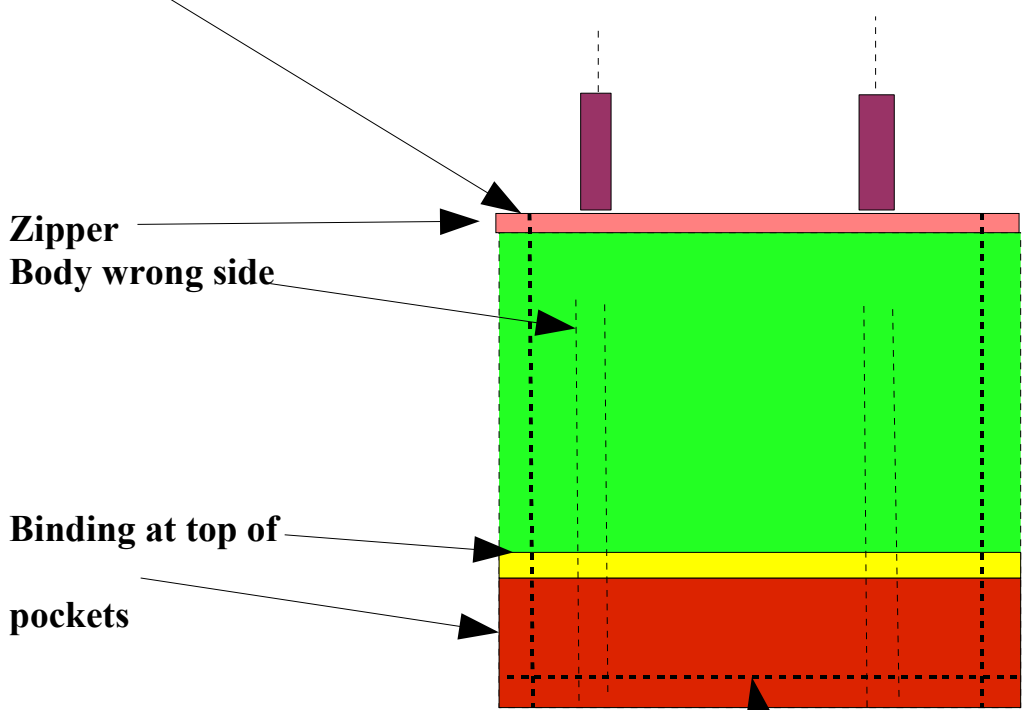

Use a small zigsag stitch at the very bottom with a stitch length of 3 and width of 3.5. Then straight stitch across the bottom with a 1/2 seam allowance.

The last step is to create a box bottom. Place your hand inside the bag at one side and spread out a triangle where the bottom and side seams meet. Use a ruler to determine when the long is 3.5" across. Mark seam line and sew across.

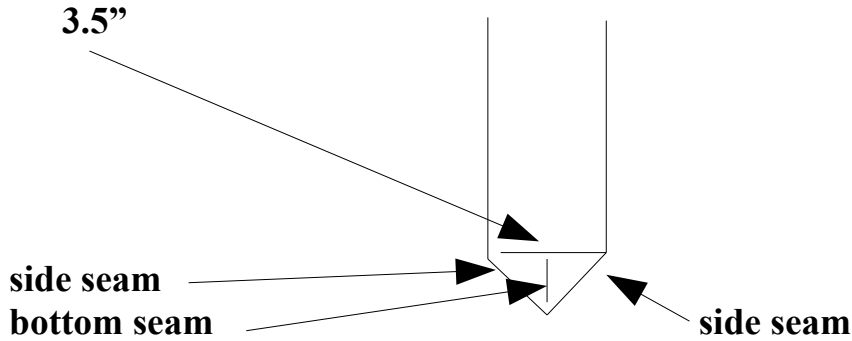

Repeat at other end of bag.

Turn bag right side out.

Your “Bonnie's” purse is complete. See instructions for a perfect companion: “Bonnie's Billfold”