

**BONNIE'S BILLFOLD****SUPPLY LIST**

**5/8 yards fabric**

**After you make a few billfolds you may want to divide up the main fabric into different fabrics: main, lining, backing, zipper section, credit card slots and binding**

- 1 7" zipper (this size is suggested rather than cutting down a larger zipper)**
- 1 3.5" section of Velcro (soft and rough pieces)**

**1.5 yards iron on interfacing such as Décor Bond**

**8 ½" x 3" vinyl**

**9 X 17" batting – thin (if thicker makes billfold too bulky)**

**Quilted fabric for outside of billfold either prequilted or you construct as follows:**

**cut 9"x 17" from main fabric**

**9" x 17" batting**

**9" x 17" backing ( will not be seen )**

**9" x 17" interfacing**

**Iron interfacing to main fabric then layer the batting and backing and quilt. A diagonal 1 inch grid sewn with the walking foot is fine. The quilted fabric will be cut down to 8 ½ " by 15 ½ " as on page 2.**

**You need a sewing machine, straight stitch foot, zipper foot and thread that matches main fabric. If you have different fabric for lining, and backing you may wish to get matching thread and either matching or contrasting thread if you do top stitching at the end. Additional optional sewing feet are non-stick foot for vinyl sewing and top stitch foot such as the Bernina 10C .**

**Special instruction for zipper placement with Steam-A-Seam2, double stick fusible Web are in Appendix I. Try it you'll like it!**

**CUTTING AND INTERFACING DIRECTIONS**

**Outside:** 9” x17” Prequilted fabric or constructed as on page 1  
cut down to 8 ½ “ x 15 ½ “ - “Main” fabric



**right side \***

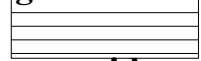

**wrong side**

**Inside:** (also called lining) this fabric either matches outside or  
is a contrasting fabric

1 - 8 ½ ” x 13 ½ “

1 - 8 ½ “ x 13 ½ “ interfacing

Iron interfacing to fabric



**right side**



**interfaced side**

**Zipper section:**

4 - 8 ½” x 8” main fabric

2 - 8 ½“ x 8” interfacing

Iron interfacing on two of the main fabric pieces



**right side**



**interfaced side**

**Credit Card Slots:**

3 - 8 ½/” x 3 ½” main fabric

3 - 8 ½” x 1 ¼” interfacing

Fold and iron the three main fabric pieces in half the long  
way. Next put the interfacing right up to fold on the inside

(wrong side) and iron on the interfacing. This make a firm top for each  
credit card slot.



**wrong side**



**Vinyl:** 1 - 8 ½” x 3”

**Binding** 2 ½ “ x 20” main fabric. Fold in ½ the long way  
and iron. 8 ½ “ pieces will be cut from the binding



**\*Color keys denote different sections even though they may be made from  
the same fabric. Wrong sides shown with hatching**

**CONSTRUCTION AND ASSEMBLY**

**Seam allowances 3/8" unless otherwise noted. In addition to "right sides" and "wrong sides", for identification purposes, section surfaces may be identified such as "surface with soft Velcro" etc.**

**Outside: This is the quilted fabric. On one short end cut corners at a 45 degree angle about 1" down from the edge.**

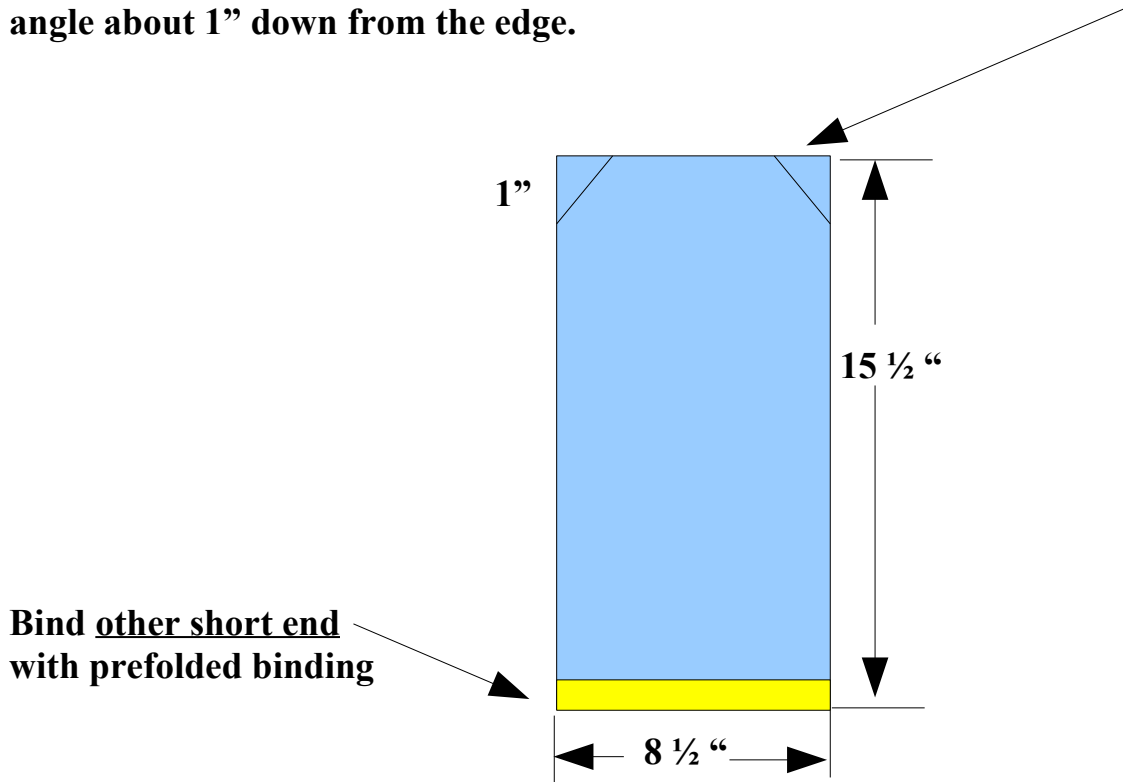

**This is the outside or right side surface of outside section. Sew soft side of Velcro 4 ¼ “ away from bound edge. Then set this Outside section aside temporarily.**

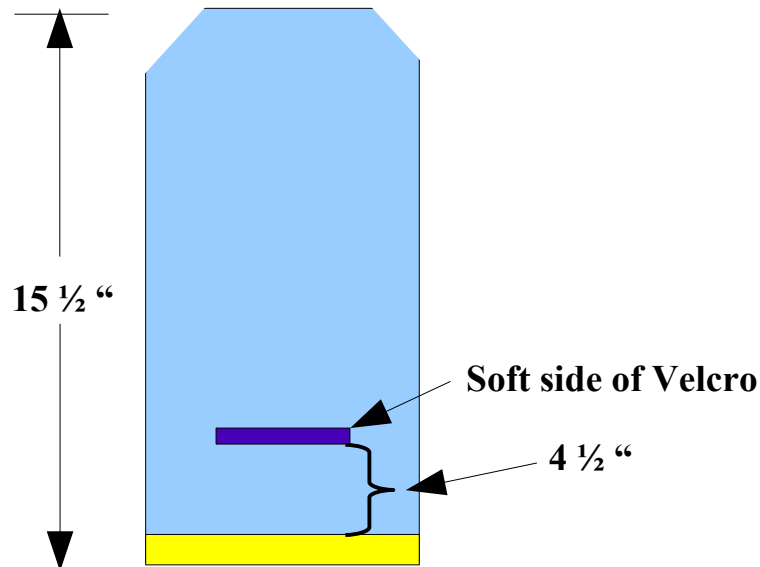

**Inside: Remember this is the 8 1/2” x 13 ½ “ section of the main ( or contrast) fabric that is unquilted and has interfacing ironed on the “wrong” side. Clean finish one short end, that is, turn under 3/8 “ and stitch. Trim corners of other end to match outside section ( 45 degree angle). On right side of fabric stitch the rough side of Velcro centered ~ ¾ ” down from short end with the 45 degree angle cuts.**

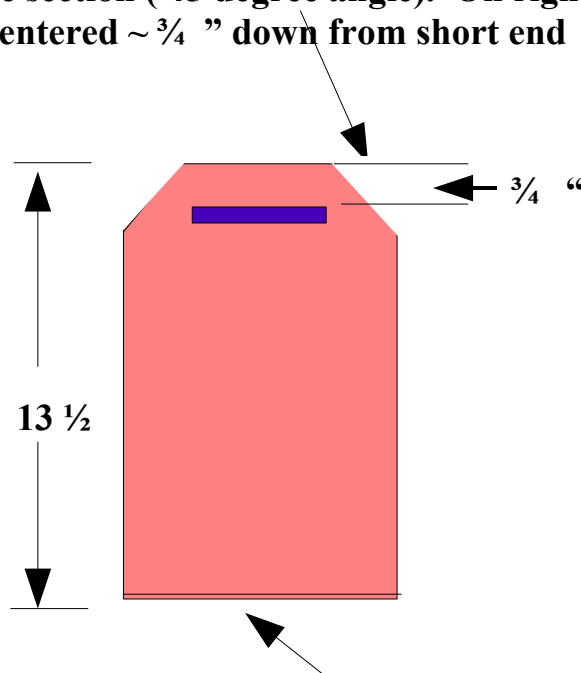

**End turned under 3/8 “ and stitched**

**Now set this section ( Inside of billfold) aside.**

**Zipper section construction next page. Also see Appendix I for other method.**

## Zipper Section Construction

a.

On your zipper section piece ( 8 " x 8 1/2" ), place zipper at the top interfaced edge, centering from left to right on the 8 1/2" side. The zipper pull should be against the right side of the fabric. Pin. Add the lining fabric (without interfacing) RST (right sides together) sandwiching the zipper between the Lining and the main fabric. Pin.

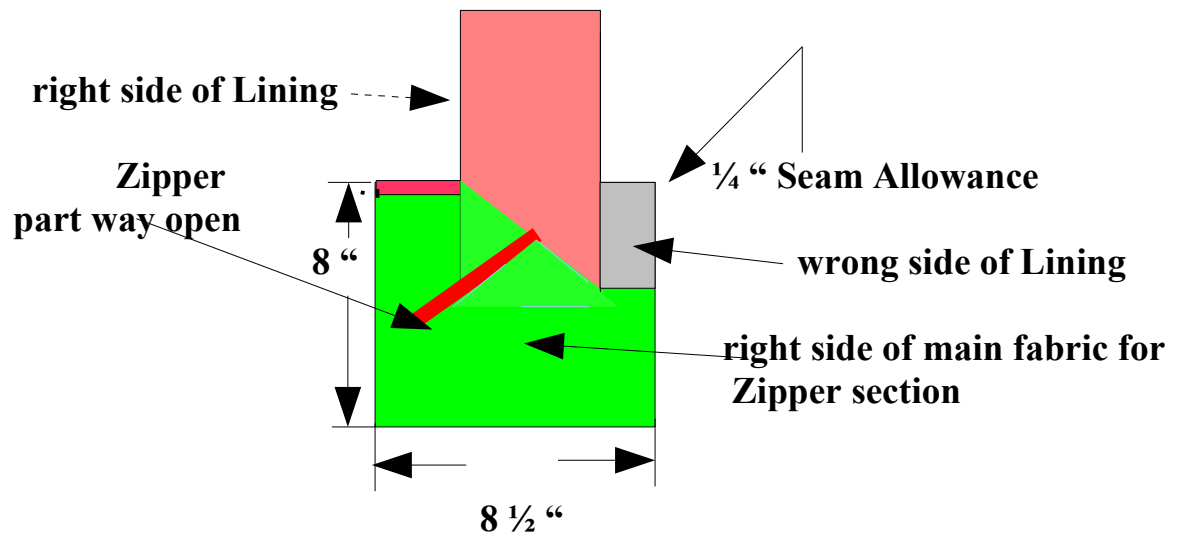

Re-pin layers together. Using your zipper foot stitch along the entire length of the fabrics with a 1/4" seam allowance, through all 3 layers. Stitch other side of zipper in same manner.

b. Press fabric sections wrong sides together and away from zipper tape. Press seam toward zipper. Edge stitch from right side of fabric close to the fold, to hold lining and outside section in place.

**You now have two layers on each side of zipper: the main fabric and the lining.**

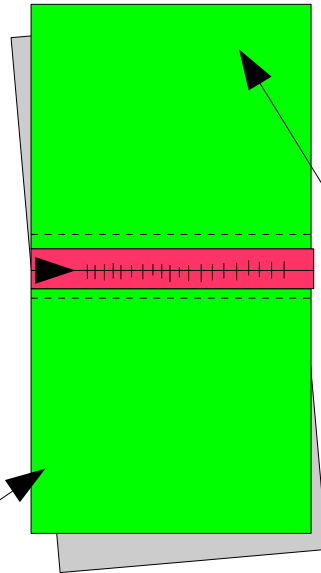

**Spread out the zipper section so the two layers are together on each side. You will be placing the credit card slots on one side with two layers and the vinyl section on the other.**

**Credit Card Slots Construction:**

**With the zipper section you just finished lying flat on the table and the pull tab on your left: place 1<sup>st</sup> credit card slot 1" from bottom and stitch across.**

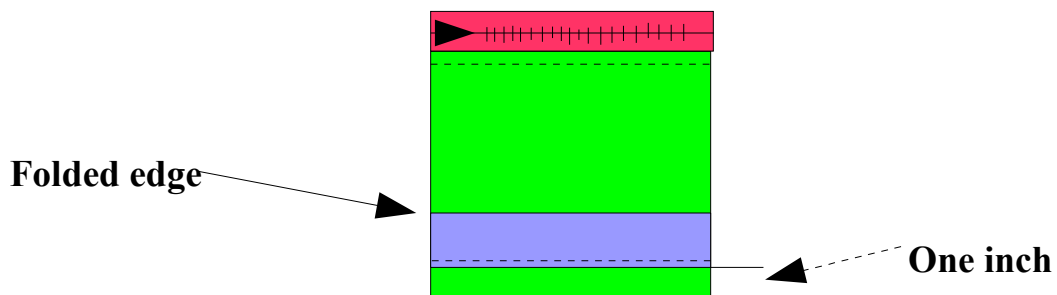

The next credit card slot should be stitched 1/2" from the bottom and the third one should be aligned at the bottom seam line.

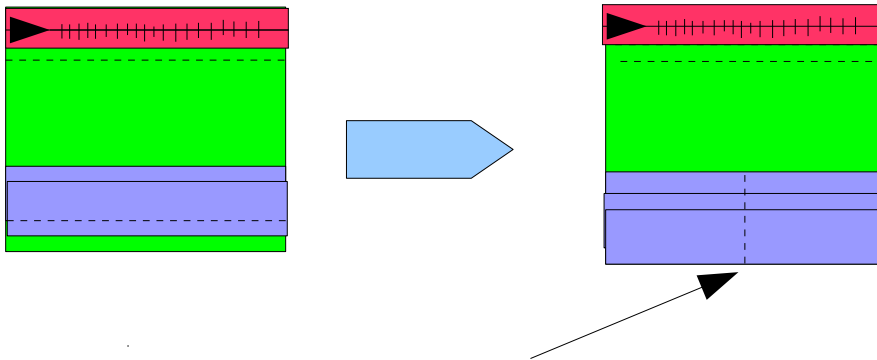

Next find the center by measurement ( $\sim 4 \frac{1}{4}$  ") and stitch through all layers, back stitch at top and bottom to complete the credit card slots.

### Vinyl Section Construction:

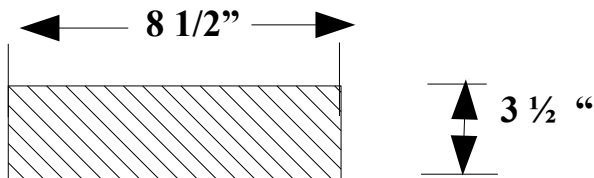

Use binding fabric previously ironed and folded in half. Cut an  $8 \frac{1}{2}$  " section. Bind one edge of the vinyl by first stitching material along raw edges approximately 1/4" from edge of vinyl. Next wrap folded edge over one long side of vinyl and stitch to vinyl. Use a special non-stick Teflon foot if available. If not, stitching may be facilitated by placing a layer of tissue paper next to vinyl surface.

Bound edge

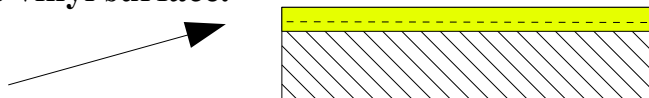

**Turn zipper section around so that zipper pull on on your right and the two layers with the credit card slots and up and out of the way.**

**Place vinyl piece with bound edge facing raw edge and 1 3/4" from raw edge.**

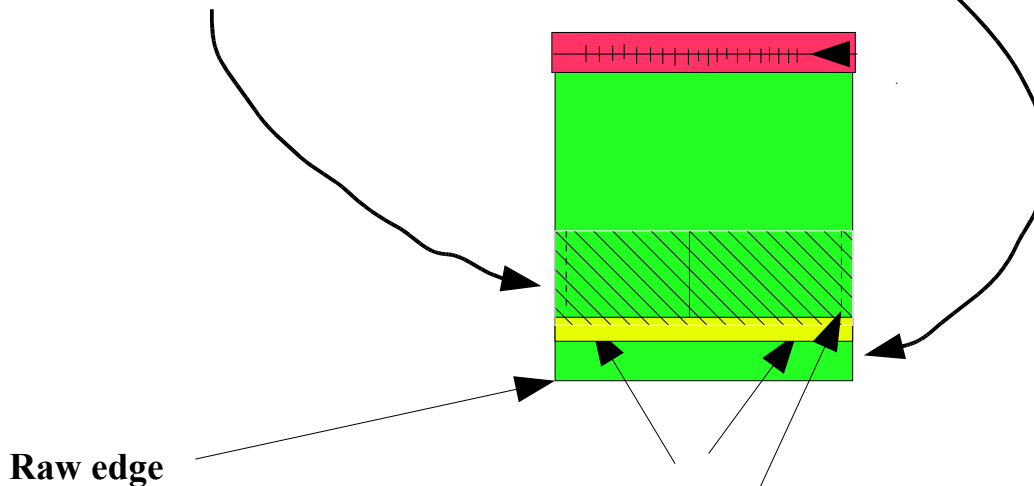

**Find center (~ 4 1/4 ") and stitch – this make two vinyl pockets. You may want to tack down the sides of the vinyl with a basting stitch.**

**Now refold the zipper section so that the layers with the credit card slots and the two layers with the vinyl pockets are inside facing each other- that is RST. The wrong side of the lining fabric should be facing you as shown below.**

**Open the zipper at least 3".**

**With right sides of zipper section together, stitch pocket sides and bottom starting 3 " down from zipper. When this stitching is done, trim corners and cut to seam at ends of stitching. Then turn so right sides, with credit card slots and vinyl section are on outside. The zipper section is complete.**

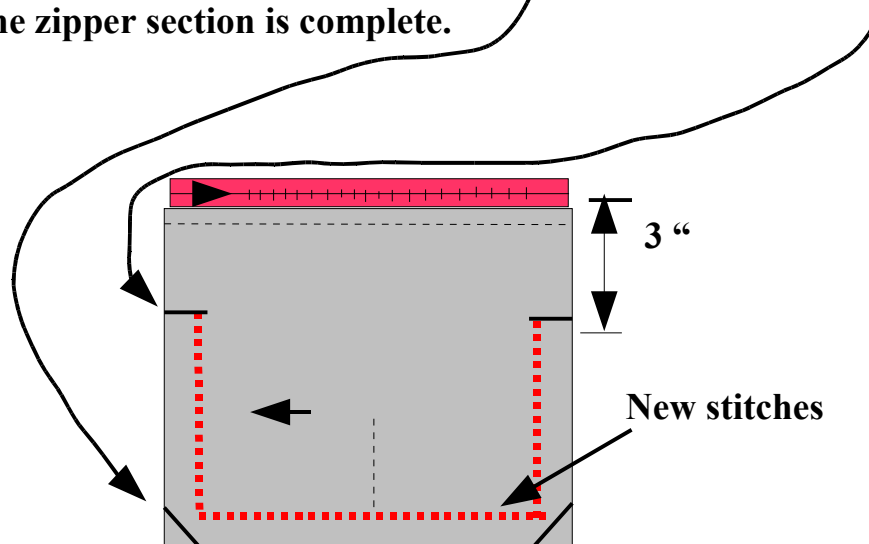

**You should now have three main sections: Outside, Inside and Zipper sections.**

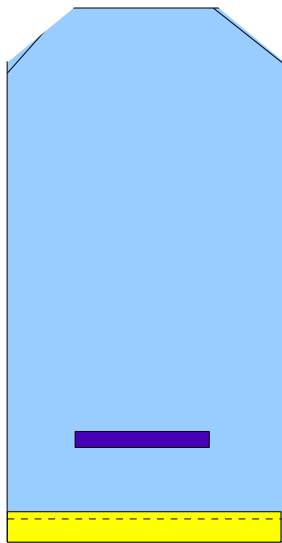

**Outside**



**Inside or Lining**

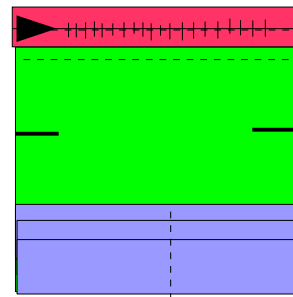

**Zipper**

**ASSEMBLY:**

**a.** Place Zipper section on Velcro surface of Lining section (zipper facing Velcro at top and credit card slots on top). Top of zipper section should be placed 4" down from clipped end with Velcro.

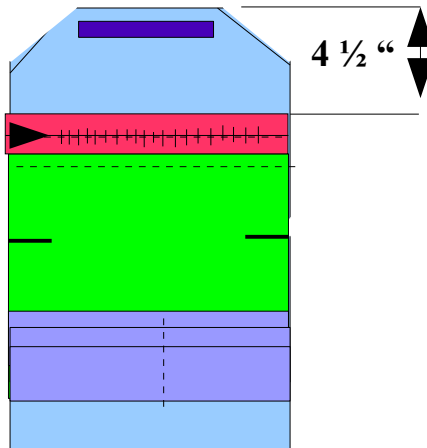

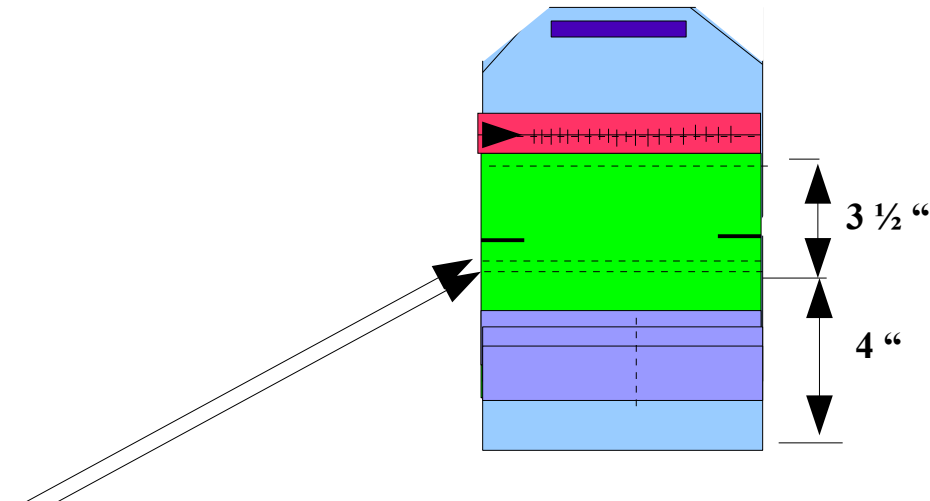

**b.** Sew two rows of stitching (very close together ~ 1/8 " apart) about 3 1/2 " from zipper and about 4 " from clean finished edge.

**c.** Take Outside quilted piece and fold up bound edge toward Velcro surface about 1 1/2 " to 2 " .

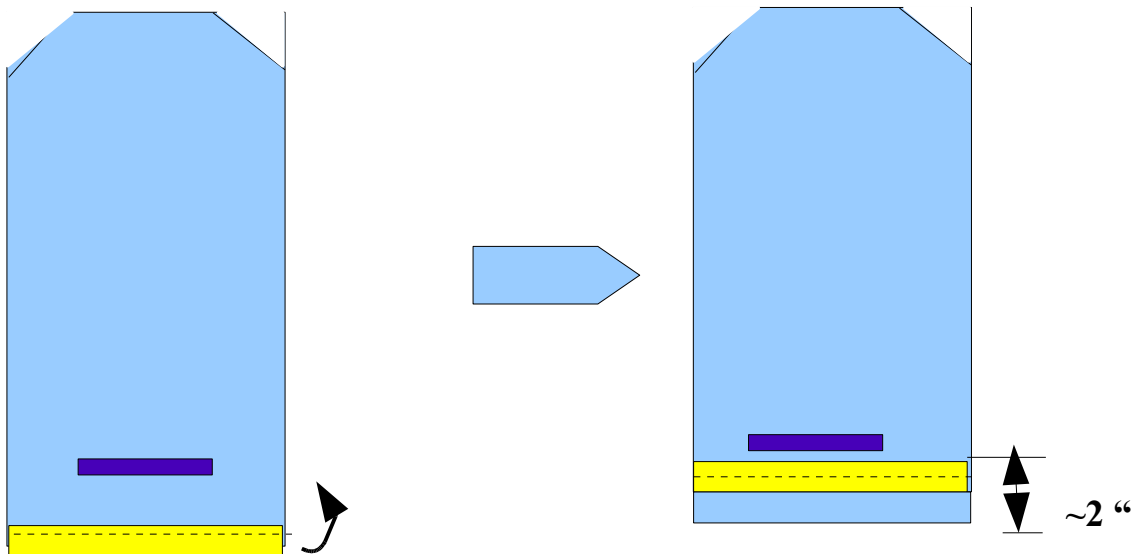

**Now make a large pocket for turning: Put right sides of lining ( Velcro surface) and right side of Outside (again Velcro surface) together. Stitch sides and top together catching the clipped edge of zipper section in seam. Leave bottom open for turning. Turn and press.**

**d.**

**Topstitch front flap with  $\frac{1}{4}$  " seam allowance**

**e. Congratulations. The first billfold is finished. The next editions should go much more quickly.**